

Tcommunicator : Economical wireless traffic System

J.Ganesh

Dept of Electronics and computer Engineering
Koneru Lakshmaiah university, Andhra Pradesh
Email: ganexplorer@yahoo.co.in

G. Chenchamma

Asst. Professor in Dept of Electronics and computer Engineering
Koneru Lakshmaiah university, Andhra Pradesh
Email-id: chenchamma_ecm@klce.ac.in

Abstract:

In order to tackle the growing no of casualties on highways due to the untimely response of emergency services on the spot a concept of multi-sensor based real time system is made. The main aim of this project is the interaction between vehicles, quick response to the emergency services on highways.. In this wireless traffic signaling system vehicle-vehicle communication will be provided by a proposed digital system known as TCOMMUNICATOR. The communication between vehicles is acknowledgment based communication. The TCommunicator is used for guiding the way to the driver at each step of the highway about the spot (ex: prediction of speed limit, Railway crossing, U turn etc) beforehand nearly 120 meters before the spot.. This communication will be most useful at night times and at dangerous spots over highways. With the help of automatic control Robot/person to control all the primary and secondary controllers. These Tcommunicator is so economical for drivers so everyone can use for their vehicles.

Keywords: Transmitter, Receiver, Control signs, Controllers GPS ,Encoder, Decoder, Emergency services, Mechanism of Locking

I. Introduction:

The topic is about the traffic communication that can be possible on the highway roads .Many of the traffic communicators are present in the market that functions as initializing a vehicle wireless subsystem; broadcasting a query to request real-time traffic pattern data, where in the real-time traffic pattern data comprises traffic pattern data obtained from other vehicle wireless subsystems and highway wireless subsystems; and if a response to the query has been received, incorporating the real-time traffic pattern data in to a runtime database and creating a human-readable display for displaying on a navigation system, wherein the human-readable display. For all these process to be done the vehicle must have a GPRS & computer system or any real time operating system and to make that system run effectively another person rather than driver has to be ,which is highly financial and can not be implement on all the speed vehicles on highway.

They are several indication for communication for drivers like waving of hand horizontally, switching lights ON & OFF and there topic really works. These topic relates to an adjustable traffic control system with a remotely controlled traffic control system having information of different signs such as STOP, Slow, Speed Limit, level Crossing ,Construction Sites, U Turn, Accident spot ,school zones ,dangerous intersections ,sharp turns,detours ,e.t.c

In these I don't want to discuss about the working of wireless digital transmission but directly giving the products that are available in the market.

Drivers travelling on roadways in their vehicles are provided with many different control signs having control information, such as,sign directed cautions, alerts and information. Sign –related information.

Thus, the effectiveness of traffic control signs to provide information to drivers is often reduced by factors or circumstances such as the placement or positioning of the signs, driver on highways incompetence, indifference or inattention, roadway limitations or impairments and/or weather conditions. Reduction or limitation of the ability to view these signs, as well as improper positioning of these signs, decreases the effectiveness of the signs and may increase the likelihood of accidents or other undesirable or unintended consequences. The proposed traffic control system Tcommunicator consists of a primary controller and secondary controller..

II. Primary Controller:

The primary controller is fixed for a large area. It is used to receive information about traffic in that area through secondary controllers. Secondary controllers send/receive information from the primary controller. Communication between the primary controller and secondary controller is done through clustered optical cables. The different functions that the primary controller used to do is automatic dialing to emergency services about accident, sending information of vehicles numbers who are travelling harshly and travelling with excess speed to traffic authorities, accessing permission to internet on highways.

III. Secondary controller:

The secondary controller mainly comprises of receivers & transmitters, encoders, decoders. The transmitters and receivers used are RF based since they can propagate for a long distance. The designing of secondary controller, receiver and transmitter will be different based on the situation and spot. Secondary controllers are mainly used to vision/traffic communication for a short distance. The main activity of the secondary is to help for communications which can be classified as

- a) Transmitter –Vehicle
- b) Vehicle – receiver
- c) Vehicle –vehicle

Mechanism of communication:

For the purpose of communication RF is used. HT12E, HT12A are the RF encoders HT12D, HT12F are the RF decoders. Based on the necessity we can use any of encoder or decoder. HT12E is a 12 bit RF encoder with RC resonator. HT12A is a 8 bit RF encoder with resonating frequency 455KHZ. HT12D is a 8bit decoder with RC Resonator. HT12F is a 12 bit decoder with RC resonator. For better output we considered 12 bit encode.decoder.

At encoder level :The 12 bits which is used to transmit is divided in to 4 parts. They are 1.controller number 2.Error control 3.Type of communication 4.Activities

Error control

The error control bit is used at the time of decoding for error prediction. We can follow parity checker, fixed number for the error prediction.

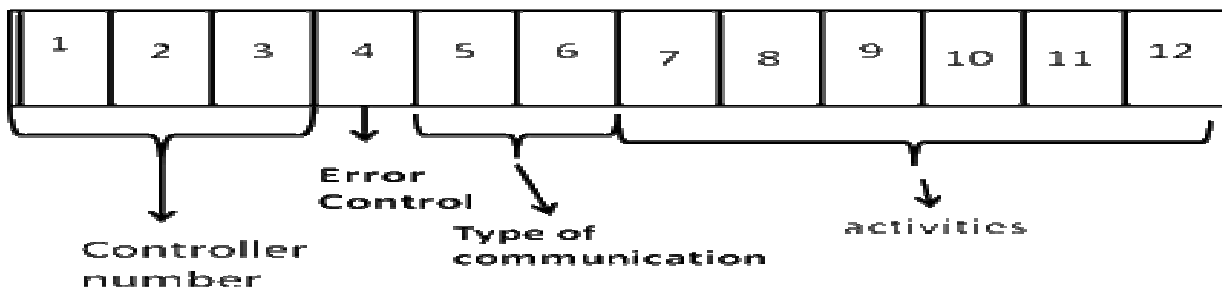

Fig1:12 bit communication mechanism

For the control number 3 bits are used based on the spot we may increase the no of bits for these controller number. In these two types of bits present they are indication bit and direction bit. The indication bit gives the place of the transmitter which helps at the time of accidents. The direction bit which will at the signal level(B0) and at the user level (u0).The decoder at the vehicle checks the each message as

If (Uo==Bo) then decode the total message else leave the message

The U0 bit must be given by the user at the starting or when he changed the direction of vehicle ,for example he want to go to left he keep U0=0 whenever he changes the direction the user has to change Uo bit. .

Type of communication

Since they are 3 different types of communication we can denote them as 3 different codes. One code is added for indication of Emergency services.

Activities

6 bits are used to indicate the different type of messages that are to be used at the time of communication.

Between the primary controller and secondary controller we use optical fibre communication so data is transmitted as packets.

a) Transmitter – vehicle communication:

For situations such as UTURN, Narrow head, sharp curves ,speed limit, stop, be ready, indication of hospital near by, level crossing e.t.c, the transmitter T1 used to transmit a code whenever it detects a object either by object detector/moving object detector and the Receiver in vehicle(RX2) used to receive the code and decode the signal and display the message either by audio voice or lcd display to the driver in the vehicle. The object detector is placed behind 100 mts based on the calculation of (max speed, min speed) at that spot. This calculation is

Time interval = [distance/(max speed) ,distance/(min speed)]

Ex: The time before user know about the spot, time of transmitting, distance is calculated as

Let distance=100 mts, speed (max 90KMPH, min 54 KMPH)

90KMPH = 25metres/sec

54KMPH =15 meters/sec

Time delay -1sec

Transmitting time nearly 3sec

Distance before the transmitter has to fixed is 120-150 mts .So the driver used to know about the spot before 12-15 sec.

The other spot where people used to suffer a lot is construction spot. In most of the countries a robotic traffic signaling device is used for reducing the need for deploying workers at various construction sites, which is high economical to implement. So we can implement our concept of TCommunicator as a part of one sign while designing of TCommunicator or we can attach a hand-like member of the statue and an assembly for rotating the sign is disposed in the body of the statue- A power source, a radio receiver, and an antenna are provided on the statue for powering the rotation assembly for communication with a remote radio transmitter. This remote radio transmitter is done by the primary controller.

The coding of messages to the receiver –vehicle is follows

Tc[5], Tc[6]= 00 (Type of communication)

In the activity block of tcommunicator i.e tc[7-12]

There is a possibility of providing a pow(2,5)=32 different messages.

And decoder in the car decodes and gives information to the driver

Ex: some of them are

Tc[7-12]	activity
000001	cross ahead
000010	u turn.....

In Technical aspects these communication is done by radio frequency remote control in which encoding of the bits at the receiver is directly given to the 12 bit rf encoder IC TX-01 at the transmitter level .the decoding of the 12 bit is done at IC RE-01.since we are RE-01 the transmitting and receiving frequency is 455Mhz..

2) Vehicle –receiver communication:

In the vehicle-receiver communication is done mainly in two aspects they are

- 1.speed limit
- 2.accident and emergency services.

For spots such as speed limit, transmitter (TX1) transmits the message of speed limit. to receivers(Rxn) which receives vehicle number are located at x meters distance and speed of the vehicle is calculated, based on the time interval between two receivers .If the time interval is below the time expected then the vehicle number is registered in the memory for judicial penalty .Design of Rxn:

The receiver Rxn, Txn is a retailted product which is mostly used in vehicles, it is rfid technology .each vehicle have a unique 8 bit no by which we can directly identify the vehicle number. The Rxn reads the vehicle number and submit the vehicle no &time to the primary controller.

a)Prediction for the excess speed limit on highways:

At the primary controller it calculates the speed basing on the database given by the Rxn1,Rxn2.

If speed limit=50KMPH if X=90 meters the time interval expected at Rxn2 =90/15 i.e. nearly 6sec. The time of receiving of vehicles no is noted at two receivers (Rxn1, Rxn2).

If((TRxn1-TRxn2)<51/2 seconds

The vehicle no. is noted for penalty due to excess speed.

b) Accident and emergency services:

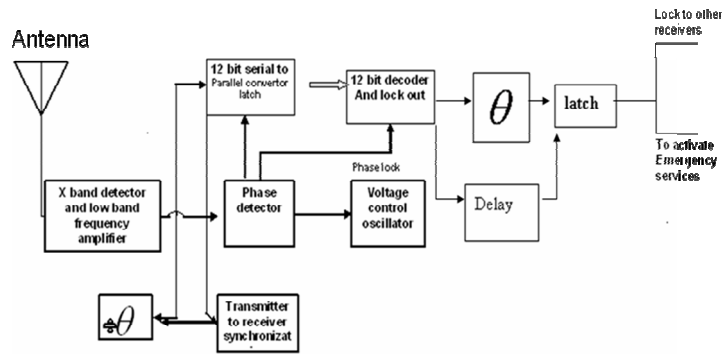
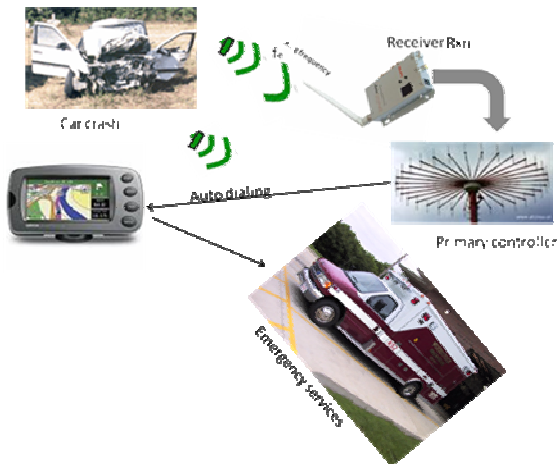

Fig4:mechanism at the time of locking

Fig 5 locking mechanism

All the transmitters, receivers which are placed on highway are fixed with a frequency lock receiver(Rxn). In situation of accident ,vehicle transmits a frequency less than 455MHZ may be nearly 332 MHZ(fe) . The Rxn receiver which is adjusted for locking the frequency fe just locks and pass the information to primary controller. which informs to the emergency services by auto dialling .

c)Vehicle – vehicle communication:

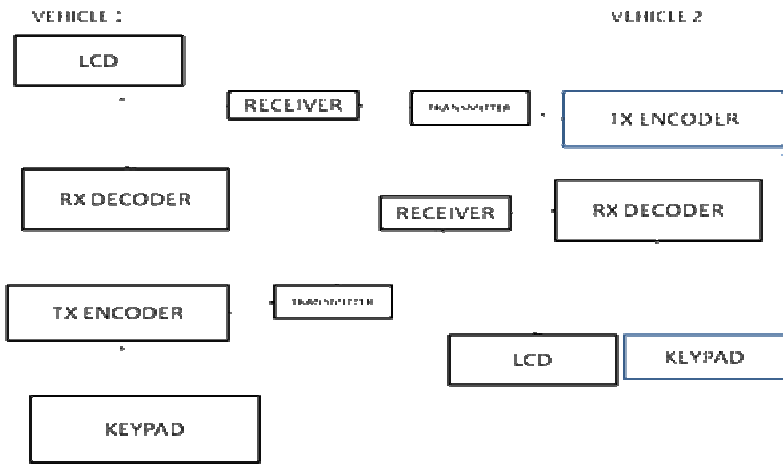

Fig 6 mechanism of vehicle-vehicle communication

In vehicle-vehicle communication the message passing is done through acknowledgements. In every vehicle there will be a transmitter and receiver in which the communication will be done . focusing on determining delay spread, probability distribution parameters (in particular, the Rician K factor) and path loss rates In all these types of communications the receiver is built with error checking controller based on the communication type i.e 5,6 bits in the 12 bit communication.

6.propagation

Signal power is attenuated as the wave passes through solid objects such as trees, walls, window and the floors of buildings.□ The signal is scattered and can interfere with itself if there are objects in the beam of the transmit antenna even if these objects are not on the direct path between the transmitter and the receive

$$\text{free space loss (Lfs)} = r^2 (4\pi)^2 / \lambda^2 .$$

The loss of energy will be more for a omni-directional antenna and we must not propagate the signal to the other hand of the highway so we use 70° directional antenna so the propagating width will be decreased and energy too.

Fig8
The antenna must be kept over a pole of height H and the propagation space must be covered over highway for a max distance of 170-190 mts of range.

6.conclusion:

The tcommunicator which acts as an friend on the highway used to give the information about the spot and situation before hand. It is also helpful at the time of accidents.since it is economical we can implement them for security for our lives and to eradicate the over traffic accidents on the highway.

References :

1. <http://www.tech-faq.com/wireless-traffic.shtml>
2. Wireless traffic control system by Gerald Charles dipiazza PUBLICATION NO”:US2005/0280553
3. <http://www.patentstorm.us/applications/pdfs/applicationId>
4. "Wireless Networks first-step" by Jim Geier
5. Wireless Communication Systems: Advanced Techniques for Signal Reception by Xiaodong Wang